

# **MIDWEST RAKE**

## **COMPANY LLC**



**High Performance Industrial/Commercial  
Floor and Surface Coating Tools**

**&**

**Decorative Concrete  
Application and Finishing Tools**

**3rd Edition**

# Why Midwest Rake Company?

- ✓ Midwest Rake Company has no minimum purchase requirements. If you need one tool, you can buy one tool...and we welcome your business. We do offer pricing discounts, depending on the dollar amount of every purchase order.
- ✓ We also drop-ship products around the world. We help you save money by doing so. Although the unit cost of a product may be a bit higher, we are equipped and experienced in providing not only technical support, but also next day delivery when the job requires it; for in fact, we have two customers for most every sale...you and your customer.
- ✓ We offer many "100% Indiana Made" tools...a difference we're proud of...an advantage to you. Sooner, not later, the "origin of products" will become a major control issue..."Where is this made?"...a question that will be more frequently asked. We do make many of our core products right here in Warsaw, Indiana. By doing so, we better control the manufacturing process and the quality outcome of many products we sell you. Making and building our own products also affords us greater control over supply and delivery schedules.
- ✓ Midwest Rake Company has a long history of creativity and innovation; from the superior bracing systems we build into our tools, the special recipe we require in the aluminum we use, and the many unique and exclusive tools we now offer. There is always a lot of pressure in our "new product" pipeline...
- ✓ The broad range of markets we serve allows our distributors to penetrate new markets; thereby capturing new sales and adding to their bottom line. Many of our distributor partners tell us that it's not just our quality that counts; they like getting such a great range of products from ONE SOURCE. Our diversity can be your gain...
- ✓ We will always strive to honor God in our pursuit of business success.

*...and there's a whole lot more...*

Please visit our website,

**midwestrake.com**

and see our **Master Catalog** for a complete overview of our entire line of quality products.

*One Company...  
serving many markets,  
when quality counts.*



# Table of Contents

**Why Midwest Rake Company? Page 2**

**Floor & Surface Coating Tools Pages 4-18**

**Surface Preparation Tools Pages 4-5**

Crack Squeegees, Scrapers, Brushes, Brooms

**Application Tools Pages 6-15**

Spiked Shoes, Application Squeegees,  
Gauge Rakes, Trowels & Floats, Smoother/  
Spreader, Application Brushes, Roller Covers  
and Frames, Ribbed Rollers

**Finishing Tools Pages 16-17**

Spiked Rollers, Roller Covers, Smoothers

**Accessories Page 18**

Mixing Paddles, Gloves, Level Pegs, Handle Options

**Terrazzo Tools & Specialty Rollers Page 19**

**Decorative Concrete Tools Page 20-22**

**Measuring Wheels & In-Store Display Unit Page 23**



*To review our complete product line  
and/or request our Master Catalog,  
please visit our website,  
[www.midwestrake.com](http://www.midwestrake.com)  
or call us at 1-800-815-RAKE (7253)*

# Surface Preparation Tools

## Crack Filler Squeegees

### Push/Pull V-Crack Filler Squeegee

This tool is designed to work as a push or pull squeegee by simply reversing the socket attachment. No tools required. The "V" is at a 70 degree angle, using a 1/4" x 2" neoprene rubber blade. The 2 inch height adds greater containment and control of material.



### Lightweight U-Crack Filler Squeegee

This squeegee is inexpensive, but effective. It is lightweight, **easy to use and is great for filling cracks prior to applying floor coatings or seal coating material.** Its replaceable blade has an inside width of 2-1/2". The blade height is 1-1/4".



For Handle Options



### Heavy-Duty U-Crack Filler Squeegee

This squeegee is **built for durability.** It has a steel frame with a 5/16" x 2-1/4" neoprene rubber blade. **The 9-1/2" deep by 3" U-shaped cavity holds plenty of material.** Replacement blades are available.



MWR Item No.	Description
46002	Lightweight U-Crack Filler Squeegee
SP50121	Replacement Blade (for 46002)
46001	Heavy-Duty U-Crack Filler Squeegee
SP50120	Replacement Blade (for 46001)
46005	Push/Pull V-Crack Filler Squeegee
SP50122	Replacement Blade (for 46005)



78916

78908

78912

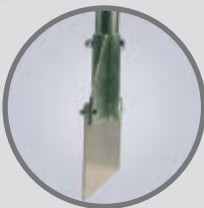

## Scrapers

**MADE IN THE USA**

A stainless steel blade, available in widths of 8", 12" and 16", attached to our super-strong, unique and durable overlapping gusset bracing system along with a 66" powder-coated aluminum handle, make this one of the most powerful scrapers on the market. **Many contractors custom grind the edge to their liking.**

Description	Blade Width		
	Item No. 8"	Item No. 12"	Item No. 16"
Stainless Steel Scraper	78908	78912	78916
Replacement Blade	SP50027	SP50028	SP50029

### Hand-Held Squeegees



### Flexible Radius Trowel



## Wire Deck & Prep Brush

This industrial size wire brush has a long handle with knuckle guard to get into hard-to-reach places. Faster results can be achieved by using a two-handed approach; apply pressure to the large oval head with one hand, while holding the handle with the other. Maximum wire content for aggressive performance. **12" overall length.**

MWR Item No.	Description
48038	Wire Deck & Prep Brush



## Wire Stripping Brush

This brush has a curved, sander-style handle that comfortably fits the palm and allows the user to press down more firmly when scrubbing. The staggered tufts, instead of rows, provide better coverage and eliminate rake marks. **6-3/4" overall length, 2-1/4" width.**

MWR Item No.	Description
48037	Wire Stripping Brush



# Brushes and Brooms

## Steel Wire Brooms

We offer two styles of aggressive steel wire brooms. These brooms are excellent for heavy scrubbing. Choose from either the **16" Round Wire Broom (47026)** or the most aggressive **12" Flat Wire Broom (47025)**. These two brooms come with either an ergonomic or straight 60" yellow powder-coated aluminum handle and our super-strong, unique gusset bracing system. The heads by themselves are also available. Trim length is 3-3/4" on the round wire and 5" on the flat wire.

## Steel Wire Brush (Long Handled)

**Spend less time on your knees and less time on a ladder.** This 7-1/4" wide brush (**47007**) has 1-1/4" long tempered steel wire bristles and comes with our superior gusset bracing system and a threaded handle adapter, or with a 60" straight or 60" ergonomic yellow powder-coated aluminum handle.

## Duo Broom

This broom (**82104, 82106**) has a highly effective sweeping action because of its **combination of strong 3" polypropylene bristles from the General Purpose Broom with an added layer of outside bristles specifically designed to sweep the finest of materials.** For maximum strength, this broom comes with our own **unique gusset bracing and a 60" ergonomic yellow powder-coated aluminum handle resulting in more broom contact with the surface to be swept. It is available in 24" and 36" widths.**

## General Purpose Broom

This 24" General Purpose Broom (**82124**) has 3" durable polypropylene bristles, firmly attached to a high quality hardwood shoulder and features our **super-strong, unique gusset bracing system** - you will not find a better braced broom. It has a **60" ergonomic yellow powder-coated aluminum handle which makes it very comfortable to use and maximizes bristle contact with the surface to be swept.**

## Street/Landscape Broom

Stiff, extra-long bristles make this 18" Street Broom (**82118**) an excellent choice when you are dealing with rough surfaces. **This broom has 5" orange poly-corn bristles and comes with our super strong unique gusset bracing and a 60" ergonomic yellow powder-coated aluminum handle.**



*A must...*

## Measuring Wheels

*You need to know the surface area first... it's just that simple.*

**85701**

**"Telescoping" handle... 4" diameter wheel**



**85712**

**Wider wheel for better balance**

**Our "Bracing" makes these brooms #1 in durability**

MWR Item No.	Description
<b>47026</b>	16" Round Wire Steel Broom with 60" Ergonomic PCAH*
<b>47036</b>	16" Round Wire Steel Broom with 60" Straight PCAH*
<b>47001</b>	16" Round Wire Steel Broom (Head Only)
<b>47025</b>	12" Flat Wire Steel Broom with 60" Ergonomic PCAH*
<b>47035</b>	12" Flat Wire Steel Broom with 60" Straight PCAH*
<b>47000</b>	12" Flat Wire Steel Broom (Head Only)
<b>47007</b>	Steel Wire Brush with Threaded Handle Adapter
<b>47027</b>	Steel Wire Brush with 60" Ergonomic PCAH*
<b>47037</b>	Steel Wire Brush with 60" Straight PCAH*
<b>82104</b>	24" Duo Broom with 60" Ergonomic PCAH*
<b>82106</b>	36" Duo Broom with 60" Ergonomic PCAH*
<b>82124</b>	24" General Purpose Broom with 60" Ergonomic PCAH*
<b>82118</b>	18" Street/Landscape Broom with 60" Ergonomic PCAH*

\*Powder-Coated Aluminum Handle

# Application Tools

*Before you start...*

**Spiked Shoes ...are a must!**

All spiked shoes come with a durable snap-lock buckle system

For walking on and in applied materials during the application and finishing processes. Standard rigid platform and "flexible" shoes are available. Spike lengths are available in lengths of 1/2" to 1". Don't leave home without 'em!



## "Flexible Bed" Spiked Shoes

made for Midwest Rake Co. by



- **Revolutionary** - perfect fit, balance and flexibility
- Toe and heel guards
- Snap-lock buckle system
- 1/2" spike length
- 20 replaceable spikes per shoe (18 per shoe on size small)
- Fits like a shoe



MWR Item No.	Description
46140	Size Small (Shoe size 6 to 7-1/2)
46141	Size Medium (Shoe size 8 to 9-1/2)
46142	Size Large (Shoe size 10 to 11-1/2)
46143	Size Extra-Large (Shoe size 12 to 13-1/2)
46129	Replacement Spikes (set of 40)

## Black Spiked Shoes

- Durable solvent-resistant polypropylene
- Snap-lock buckle system
- **Sharp or Rounded tip spikes**
- 13 specially placed spikes per shoe
- Replacement spikes (see below)

## Steel Spiked Shoes

- More flexible and durable
- Snap-lock buckle system
- 3/4" or 1" spike lengths
- Replacement spikes (see below)

## Red "Acid-Resistant" Spiked Shoes

- 3/4" acid-resistant stainless steel spikes
- Acid-resistant footbeds
- Snap-lock buckle system
- Replacement spikes (see below)

Non-puncturing rounded tip available



A. / B. / C.



D. / E.



F.

MWR Item No.	Description
A. 46106	Black Spiked Shoes 3/4" sharp spikes (pair)
B. 46107	Black Spiked Shoes 1" sharp spikes (pair)
C. 46112	Black Spiked Shoes 3/4" rounded spikes (pair)
D. 46103	Steel Spiked Shoes with 3/4" spikes (pair)
E. 46104	Steel Spiked Shoes with 1" spikes (pair)
F. 46108	Red "Acid-Resistant" Spiked Shoes (pair)

MWR Item No.	Description
46120	Replacement Straps for A, B, C and F (set of 4 - 2 each shoe)
46121	Replacement Straps for D and E (set of 6 - 3 each shoe)
46122	3/4" Rounded Tip Replacement Spikes for C (set of 26 - 13/shoe)
46125	3/4" Sharp Tip Replacement Spikes for A & D (set of 26 - 13/shoe)
46126	1" Sharp Tip Replacement Spikes for B & E (set of 26 - 13/shoe)
46128	3/4" Acid Resistant Replacement Spikes for F (set of 26 - 13/shoe)

Customize your own...

**EXCLUSIVE  
MADE IN THE USA**

# Application Squeegees

## 1 Choose the frame

Midwest Rake Company application squeegee frames are the standard in the Protective Coating industry. **These "clamp-style" frames make it easy to change blades. The unique gusset bracing and threaded handle adapter are the most durable on the market.** The solvent-resistant aluminum frames are available with a powder-coated aluminum handle in a 66" or 82" length or with a threaded handle adapter. These are quality frames that can be used over and over again, requiring only the purchase of replacement blades (see below).



"Clamp-Style" Frame

Description	Frame Width				
	Item No. 16"	Item No. 24"	Item No. 30"	Item No. 36"	Item No. 48"
Application Squeegee Frame with THA*	78000	78010	78015	78020	78040
Application Squeegee Frame with 66" PCAH**	78100	78110	78115	78120	78140
Application Squeegee Frame with 82" PCAH**	78200	78210	78215	78220	78240

### Helpful Hint...

So how thick is 10 mils...or 20 mils? A lot thinner than most people think. 10 mils is the thickness of an average business card. An 1/8" slurry is 125 mils..."It's a thin world after all!"

No squeegee blade or blade manufacturer can guarantee a final mil thickness (or thinness)...there are just too many factors that influence final coating thickness. Ask the technical specialist of any coating manufacturer, then use a "gauge" along the way.

## 2 Choose the blade

Midwest Rake Company application squeegee blades are available in **Neoprene, EPDM and Red Rubber**. The **Neoprene** and **EPDM** blades are "reversible" (notched on both sides). The **Red Rubber** blades are notched on one side and no-notch (flat) on the other side. Each type is available in a variety of head widths and notch sizes. **Neoprene** blades are best for water-based or oil and petroleum based coating products. **EPDM** blades are best for solvent-based coatings and clear coats. The 2" **Red Rubber** blades are solvent-resistant and offer more flexibility in any floor coating application use. They are "non-marking" and display good solvent tolerance.



Neoprene



EPDM



Red Rubber



**EXCLUSIVE**  
Rubber is also available by the roll.

Our standard **Neoprene, EPDM and Red Rubber** is available in **25' rolls**. Please see the chart below for product information.

Description	Standard Neoprene	Standard EPDM	2" Red Rubber
	Notched on both sides	Notched on both sides	Notched on one side only
25' Roll No-Notch (Flat) Rubber	79405	79505	79605
25' Roll 1/8" Notch Rubber	79410	79510	79610
25' Roll 3/16" Notch Rubber	79415	79515	79615
25' Roll 1/4" Notch Rubber	79420	79520	79620
25' Roll 3/8" Notch Rubber	79425	79525	79625
25' Roll 1/2" Notch Rubber	79430	79530	79630

Description	Blade Width				
	Item No. 16"	Item No. 24"	Item No. 30"	Item No. 36"	Item No. 48"
<b>NEOPRENE</b> No-Notch (Flat) <b>Reversible</b> Squeegee Blade	79005	79010	79013	79015	79020
<b>NEOPRENE</b> 1/8" Notch <b>Reversible</b> Squeegee Blade	79025	79030	79033	79035	79040
<b>NEOPRENE</b> 3/16" Notch <b>Reversible</b> Squeegee Blade	79045	79050	79053	79055	79060
<b>NEOPRENE</b> 1/4" Notch <b>Reversible</b> Squeegee Blade	79065	79070	79073	79075	79080
<b>NEOPRENE</b> 3/8" Notch <b>Reversible</b> Squeegee Blade	79085	79090	79093	79095	79100
<b>NEOPRENE</b> 1/2" Notch <b>Reversible</b> Squeegee Blade	79105	79110	79113	79115	79120
<b>EPDM</b> No-Notch (Flat) <b>Reversible</b> Squeegee Blade	79205	79210	79213	79215	79220
<b>EPDM</b> 1/8" Notch <b>Reversible</b> Squeegee Blade	79225	79230	79233	79235	79240
<b>EPDM</b> 3/16" Notch <b>Reversible</b> Squeegee Blade	79245	79250	79253	79255	79260
<b>EPDM</b> 1/4" Notch <b>Reversible</b> Squeegee Blade	79265	79270	79273	79275	79280
<b>EPDM</b> 3/8" Notch <b>Reversible</b> Squeegee Blade	79285	79290	79293	79295	79300
<b>EPDM</b> 1/2" Notch <b>Reversible</b> Squeegee Blade	79305	79310	79313	79315	79320
<b>RED RUBBER</b> No-Notch (Flat) Squeegee Blade	79705	79710	79713	79715	79720
<b>RED RUBBER</b> 1/8" Notch Squeegee Blade	79725	79730	79733	79735	79740
<b>RED RUBBER</b> 3/16" Notch Squeegee Blade	79745	79750	79753	79755	79760
<b>RED RUBBER</b> 1/4" Notch Squeegee Blade	79765	79770	79773	79775	79780
<b>RED RUBBER</b> 3/8" Notch Squeegee Blade	79785	79790	79793	79795	79800
<b>RED RUBBER</b> 1/2" Notch Squeegee Blade	79805	79810	79813	79815	79820

\*Threaded Handle Adapter \*\*Powder-Coated Aluminum Handle



# Application Squeegees - *Frame & Blade "Combo"*

*...you supply only the handle*



For Handle Options

**Most Popular**

Description	Frame Width	
	Item No. 16"	Item No. 24"
Application Squeegee Frame with <b>No-Notch (Flat)</b> Reversible <b>EPDM</b> Blade with THA*	<b>78546</b>	<b>78554</b>
Application Squeegee Frame with <b>No-Notch (Flat)</b> <b>Red Rubber</b> Blade with THA*	<b>78548</b>	<b>78556</b>
Application Squeegee Frame with <b>1/8" Notched</b> Reversible <b>EPDM</b> Blade with THA*	<b>78118</b>	<b>78128</b>
Application Squeegee Frame with <b>1/8" Notched</b> <b>Red Rubber**</b> Blade with THA*	-	<b>78129</b>
Application Squeegee Frame with <b>3/16" Notched</b> Reversible <b>EPDM</b> Blade with THA*	<b>78116</b>	<b>78126</b>
Application Squeegee Frame with <b>3/16" Notched</b> <b>Red Rubber**</b> Blade with THA*	-	<b>78323</b>
Application Squeegee Frame with <b>1/4" Notched</b> Reversible <b>EPDM</b> Blade with THA*	<b>78114</b>	<b>78124</b>
Application Squeegee Frame with <b>1/4" Notched</b> <b>Red Rubber**</b> Blade with THA*	-	<b>78125</b>

\*Threaded Handle Adapter **\*\*Red Rubber blades are flat on the reverse side**

## Hand-Held Squeegees

*Hand-Held Squeegee* **EXCLUSIVE**

You can go back again and again to the hardware store or home center to buy window squeegees, or you can just change the 8" wide blade in this quality built, hand-held squeegee. It is used to fill depressions and cracks in a floor prior to the application of any protective coating product. You can also use it to spread any material, including slurries and highly viscous and cementitious mixes. **It comes with a choice of a 3" flexible rounded edge neoprene blade, or a 1-1/2" more rigid square edge neoprene blade.** The blade is clamped in a durable 11" long x 8" wide aluminum frame, not bolted through, making it easy to replace. The handle is a 6" non-slip vinyl grip over an aluminum core.



**78708**

**Want a different blade? Well, buy any option of our 16" squeegee blades on page 7, cut it in half...and you've got a new blade and a spare.**

### Window Squeegee

OK, for those of you who are still not convinced or just plain lack any sense of adventure...here it is...a 10" hand-held window squeegee. Blade is replaceable.

MWR Item No.	Description
<b>78708</b>	Hand-Held Squeegee with 3" Round Edge Neoprene Blade
<b>SP50052</b>	Replacement Blade for 78708
<b>78709</b>	Hand-Held Squeegee with 1-1/2" Square Edge Neoprene Blade
<b>SP50129</b>	Replacement Blade for 78709
<b>78710</b>	Window Squeegee
<b>SP50130</b>	Replacement Blade for 78710



**78710**

*Tapered Handle Available - See page 18*

## Flexible Radius Squeegee/Trowel

This highly versatile, **solvent-resistant rubber hand tool** (may be used with a handle, see page 18) with flexible wings is **ideal for the application of higher viscosity waterproofing, floor coating and sealing materials and along floor edges, for crack and patch filling on floors, and for the creation of a rounded radius along straight and radial edges when applying many different cementitious materials such as epoxy patching mortar on floors.** The flexible wings conform to any corner or floor edge, providing for the smooth application of material. This is a flexible tool for coating and sealing many of the most difficult areas that need to be well sealed. **You can't limit this tool to a single use;** it has cross-over coating applications in all of the markets we serve, from floor coating to waterproofing, roofing, etc. **This is truly one of those, "I gotta try it" tools.** The wing width is 6-1/2" and the length is 9-1/2". A 1" diameter handle may be used with this tool.



MWR Item No.	Description
<b>46010</b>	Flexible Radius Trowel / Squeegee

# Gauge Rakes *...are a Contractor's best friends*

Midwest Rake Company offers two styles of gauge rakes for self-leveling floor coatings. Choosing which one to use depends on the type of floor coating application, condition of the substrate surface, or personal preference. The **CAM® Gauge Rake** (our favorite) with 2 contact points is generally recommended when thicker material is being spread, but it will gauge 1/32" depths. It also works best in situations where the substrate surface is smooth. The **Wire Gauge Rake**, with its six wire contact points, works best with more fluid materials. The greater number of contact points allows for a smooth application over a substrate surface with moderate pocking. We highly recommend that you check with your coating product manufacturer to determine the model best suited for your needs.

**The CAM® Gauge Rake is a "goof-proof" exclusive, patented tool designed for the easy application of coating material at pre-set and uniform depths ranging from 1/32" to 1-1/2". This is a "must-have" tool for floor coating applicators and decorative concrete contractors.** It is used for the application of a variety of self-leveling epoxies and higher mil coating products. It is also a favored tool for the spreading of slurry-like, higher viscosity and cementitious base materials at a precise and uniform depth prior to stamping or the decorative concrete treatment of concrete or other surfaces.

**The Wire Gauge Rake is used to apply self-leveling floor coatings and lower viscosity materials. The adjustable aluminum gate can be set to any desired thickness from 0" to 5/8".** The six radial contact points help maintain the desired level or depth of application when dealing with uneven substrates.

*Helpful Hint...*  
In many applications, gauge rakes can do the work in half the time it takes to use a squeegee...and with greater precision.

## Wire Gauge Rakes

**EXCLUSIVE  
MADE IN THE USA**



**58624**



**58609**



Radial contact points for a smoother push/pull action

*The **Wire Gauge Rake** is used to apply self-leveling floor coatings and lower viscosity materials. It is far superior to pin-type gauge rakes on the market. The strong spring-steel wires are formed in a "radial" or loop fashion. This eliminates chatter and vibration common with pin-type gauge rakes. The multiple contact points make this tool an excellent choice when working on pitted or uneven surfaces, as some of the points will maintain the desired level or depth of application even at varying handle angles and lengths. The adjustable aluminum gate or bar can be set to any desired thickness from 0" to 5/8". Replacement wires are available. **Ordering replacement wire sets is encouraged.***

Description	Frame Width		
	Item No. 14"	Item No. 24"	Item No. 36"
<b>Wire Gauge Rake</b> with Threaded Handle Adapter	<b>58714</b>	<b>58609</b>	<b>58734</b>
<b>Wire Gauge Rake</b> with 66" Powder-Coated Aluminum Handle	-	<b>58624</b>	<b>58736</b>
<b>Wire Gauge Rake</b> with 82" Powder-Coated Aluminum Handle	-	<b>58824</b>	<b>58738</b>
Product Description	Item No.		
Replacement Wire Set (Set of 3 wires)	<b>68611</b>		
Replacement Wire Set (Set of 4 wires for 36" width)	<b>68616</b>		

# CAM® Gauge Rakes

A patented "goof-proof" tool which applies a range of materials at a precise, specified, and uniform depth. For use in applying decorative concrete "toppings," self leveling/high performance floor coating materials, and underlayments in the floor-covering markets. CAM® depth settings range from 1/32" to 1-1/2". A must have tool for the decorative concrete and floor coating contractor. The CAM® Gauge Rake is comprised of an aluminum frame that comes with either a threaded handle adapter or a powder-coated aluminum handle. **Choose your frame size and handle option and then choose your CAM® set (set of 2).** When one contact point wears down, you simply loosen the wing nut and rotate the CAM® to a fresh contact point. We use a "radial" edge design which maintains uniform coating thickness, even at varying handle angles and lengths.

## CAM® Gauge Rake Frames

**MADE IN THE USA  
EXCLUSIVE**

**CAM® Gauge Rake Frames and CAM® Sets are sold separately**

- Head widths range from 10" (hand held) to 48". The 24" and 36" widths are the most popular. CAM® sets come in depth settings ranging from 1/32" to 1-1/2" with the 1/8", 1/4", and 3/8" CAM® sets being the most popular.
- Each CAM® has multiple contact points of the same depth... when worn down, loosen the wing nut and rotate the CAM® for a fresh contact point of the same depth setting.
- The CAM® Gauge Rake is available with a milled threaded handle adapter or a 66" powder-coated aluminum handle. The 10" CAM® Rake is used for small areas and counter tops and has its own fixed handle with grip.

24" frame with 66" handle  
**57001**

**CAM® sets sold separately**

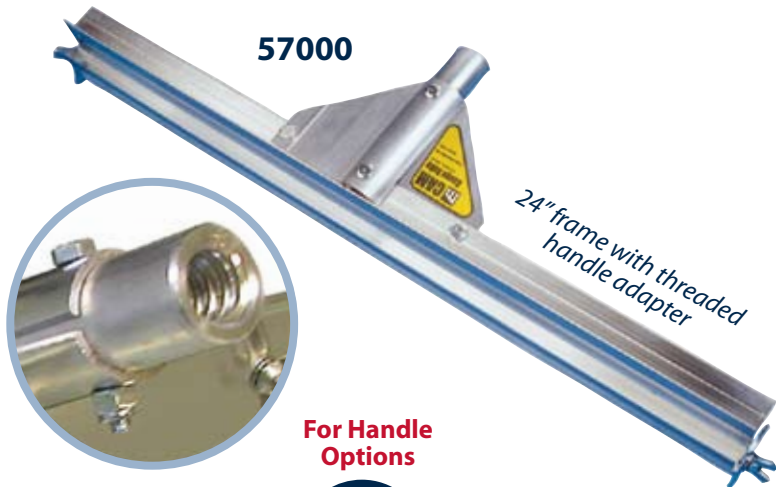

**For Handle Options**



**CAM® sets sold separately**



**CAM® sets sold separately**

### Frame Width

Description	Item No. 12"	Item No. 24"	Item No. 36"	Item No. 48"
<b>CAM® Gauge Rake</b> with Threaded Handle Adapter (Frame Only)	<b>57030</b>	<b>57000</b>	<b>57010</b>	<b>57020</b>
<b>CAM® Gauge Rake</b> with 66" Powder-Coated Aluminum Handle (Frame Only)	<b>57031</b>	<b>57001</b>	<b>57011</b>	<b>57021</b>
<b>CAM® Gauge Rake</b> with 82" Powder-Coated Aluminum Handle (Frame Only)	<b>57032</b>	<b>57002</b>	<b>57012</b>	<b>57022</b>

## CAM® Gauge Rake CAM® Sets

We use a "radial" edge CAM® design which maintains uniform coating thickness, even at varying handle angles and lengths.



**CAM® Gauge Rake Frames and CAM® Sets are sold separately**



Larger CAM® Sets:

**5/8" CAM® Set  
57090 (size 10)  
3 settings**

**1" CAM® Set  
57096 (size 16)  
3 settings**

**1-1/2" CAM® Set  
57104 (size 24)  
2 settings**

**Our Most Popular Sizes**



1/16" - 57081



1/8" - 57082



1/4" - 57084



1/32"	1/24"	1/16"	1/8"	3/16"	1/4"	5/16"	3/8"	1/2"
<b>57078</b>	<b>57079</b>	<b>57081</b>	<b>57082</b>	<b>57083</b>	<b>57084</b>	<b>57085</b>	<b>57086</b>	<b>57088</b>
<b>Size A</b>	<b>Size B</b>	<b>Size 1</b>	<b>Size 2</b>	<b>Size 3</b>	<b>Size 4</b>	<b>Size 5</b>	<b>Size 6</b>	<b>Size 8</b>

## CAM® Sets are also available in "3-packs"...

MWR Item No.	Description
<b>57180</b>	CAM® 3 Pack - 1 Set (2) each, Size 1 (57081), 2 (57082) and 4 (57084)
<b>57181</b>	CAM® 3 Pack - 1 Set (2) each, Size 2 (57082), 4 (57084) and 6 (57086)

Level "Pegs"

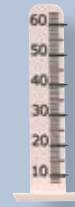

★ *Customize your own...*  
**CAM® Gauge Rake**  
*...or choose a*  
**Frame & Blade "Combo"**  
*(you supply only the handle)*

**Now you can order the exact tool you use most.** These gauge rakes come with a 24" wide frame and 1 CAM® set. Four different sizes of CAM® sets are available. Simply attach a handle and you have a complete tool. See all of our handle options on page 18. Replacement CAM® sets are available, see above for all sizes.

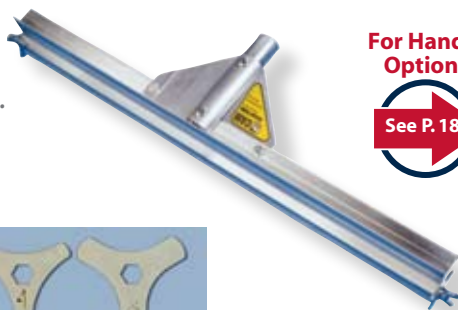

For Handle Options

See P. 18



MWR Item No.	Description
<b>57201</b>	24" CAM® Gauge Rake <b>with size 1 (1/16") CAM® Set</b> , THA*
<b>57202</b>	24" CAM® Gauge Rake <b>with size 2 (1/8") CAM® Set</b> , THA*
<b>57204</b>	24" CAM® Gauge Rake <b>with size 4 (1/4") CAM® Set</b> , THA*
<b>57206</b>	24" CAM® Gauge Rake <b>with size 6 (3/8") CAM® Set</b> , THA*

\*Threaded Handle Adapter

## "Sled" Style Gauge Rakes

These **self-adjusting** gauge rakes have been used for many years. Although not as precise as our other gauge rakes shown, they are **value priced**, will allow you to achieve a reasonably level depth when installing more cementitious materials, and **do allow you to more easily move over rougher surfaces.** **Styles and colors may vary, but the "sled-style" self-adjusting features of these gauge rakes will be "standard" characteristics of anything available in this category.** **...and our handle adapter is "threaded"**

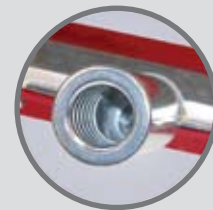

MWR Item No.	Description
<b>58420</b>	24" Sled-Style Gauge Rake
<b>58425</b>	36" Sled-Style Gauge Rake

# Trowels & Floats MADE IN THE USA

Tempered, ground and polished high carbon spring steel. Blades are fastened with hardened steel rivets. Wooden handles for better gripping power. Selected by manufacturers' "technical specialists" for decorative concrete and floor coating applications. Hard to find sizes...



## Rounded End Trowels

- 4" x 16" - 47465
- 4" x 18" - 47466**
- 3" x 12" - 47475
- 3" x 16" - 47477

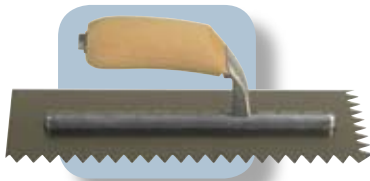

## Notched Trowels

- 11" x 4-1/2" overall
- 3/16" V-Notch - 47406**
- 1/4" V-Notch - 47403
- 1/2" V-Notch - 47402

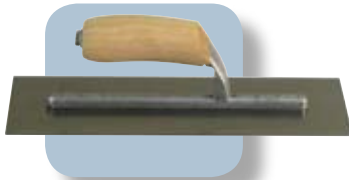

## Finishing Trowels

- 4" x 12" - 47404
- 4" x 16" - 47405

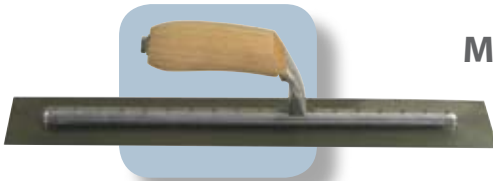

## Epoxy Mortar Trowels

- 3" x 12" - 47460**
- 3" x 16" - 47461**



## Cove Trowels High Carbon Blue Steel

- Heavy-Duty 1" Radius**
- 7-1/2" x 5-3/4" x 3-1/2" - 47414
- Heavy-Duty 3/4" Radius**
- 7-1/2" x 5-3/4" x 3-1/2" - 47409
- Economy Regular 1" Radius**
- 4" x 3" x 6" - 47411
- 6" x 3" x 6" - 47412



## More Flexible "Spring Form" Trowel

Shorter rib, more flexibility

- 5" x 16" - 47470**

# Raised Edge Border/Hand Floats

Heavy-duty raised edges "all-around" make these hand floats / smoothers / trowels ideal tools for any decorative concrete contractor... no cutting edges and a great tool when working with higher viscosity / cementitious materials and other "trowelable" materials.



MWR Item No.	Description
<b>47500</b>	8" x 6" Stainless Steel Float
<b>47510</b>	15" x 6" Float

# Flexible Radius Trowel

This is a flexible tool for coating and sealing many of the most difficult areas that need to be well sealed. You can't limit this tool to a single use; it has cross-over coating applications in all of the markets we serve, from floor coating to waterproofing, roofing, etc.



MWR Item No.	Description
<b>46010</b>	Flexible Radius Trowel / Squeegee

# ★ Smoother/Spreader

This tool is lightweight, yet durable. It features a 22" frame with a 23-1/2" x 2" heat-treated steel blade, fan-shaped for next to wall coverage, and a reversible "threaded" handle adapter assembly allowing for use as a smoother or spreader. Spread material with the blade in a vertical position (see below). Flip the tool over and smooth the surface as shown. This is a "core" tool...

See handle options on page 18  
Use #SP20215 (wood) or aluminum powder-coated handle.



Long handled "troweling" action, too...



MWR Item No.	Description
<b>78930</b>	Smoother with Threaded Handle Adapter

# Application Brushes

## Epoxy/Thick Fluid Coating Brush

This 13" hand-held brush has a 6" wide block with 3-1/2" tampico bristles that are strong and chemical resistant. This brush provides fast, thorough coverage of all materials ranging from epoxies and water-proofing to base coat and roofing materials. It is ideal for applications in tight places or for any quick coating needs.



Block size  
6" x 1-3/4"

## Protective Coating Brush

Polypropylene bristles in combination with a squeegee blade make this an ideal protective coating application tool when applying a range of products when coverage is more important than a specific mil thickness. This tool is used extensively when resurfacing asphalt surfaces such as driveways, when coating garage floors, work areas and when applying waterproofing and roofing materials...an excellent DIY tool, as well. Braces are available below and we recommend using this tool with our hardwood handle with metal threaded tip (SP20215 or SP20216 - see page 18.)



18" Head Width

For Brooms



MWR Item No.	Description
48035	Epoxy/Thick Fluid Coating Brush
47240	18" Protective Coating Brush with Squeegee Blade (Head Only)
SA30502	Aluminum Wrap-Around Braces for Protective Coating Brush

# Roller Covers

## Premium Roller Covers

These roller covers are available in a shed-resistant woven mohair-blend or a shed-resistant woven fabric in 9" and 18" widths with various nap lengths. Please see the chart below for details.



1/4" Holed End Caps

## Pro-Grade Roller Covers

These roller covers are available in a shed-resistant woven fabric in 9" and 18" widths and in extra long widths of 24" and 36", with various nap lengths. These rollers are sold individually and in 12-Packs. Please see the chart below for more details.

### Helpful Hint...

No roller cover is 100% shed resistant...we suggest running tape over the roller cover prior to application.



**Please Note: Only our "Premium" 18" roller covers come with end caps. All other roller covers come without end caps.**

MWR Item No.	Description
SA30005	1/4" End Caps (Set of 2)
SA30042	1/4" End Caps (Box of 24)

Description	Roller Width	Nap Length 1/4"	Nap Length 3/8"	Nap Length 1/2"	Nap Length 3/4"
A. Premium <b>Mohair Blend</b> (Red Stripe) Roller Cover	9" (no end caps)	48020	-	-	-
B. Premium <b>Mohair Blend</b> (White) Roller Cover	9" (no end caps)	48022	-	-	-
C. Premium <b>Mohair Blend</b> (White) Roller Cover	18" (with end caps)	48021	-	-	-
D. Premium <b>Woven Fabric</b> (Gold Stripe) Roller Cover	9" (no end caps)	-	48023	48026	-
E. Premium <b>Woven Fabric</b> (Gold Stripe) Roller Cover	18" (with end caps)	-	48024	48028	-
F. Pro-Grade Woven Shed Resistant Roller Cover	9" (no end caps)	48202	48203	48204	48206
Pro-Grade Woven Shed Resistant Roller Cover	18" (no end caps)	48208	48209	48210	48211
Pro-Grade Woven Shed Resistant Roller Cover	24" (no end caps)	-	48040	48042	48044
Pro-Grade Woven Shed Resistant Roller Cover	36" (no end caps)	-	48050	48052	48054
Pro-Grade Woven Shed Resistant Roller Cover <b>12 Pack</b>	9" (no end caps)	48002	48003	48004	48006
Pro-Grade Woven Shed Resistant Roller Cover <b>12 Pack</b>	18" (no end caps)	48008	48009	48010	48011

# Specialty Roller Covers



These shed-resistant 1/4" nap **Epoxy Roller Covers** exhibit great pick up, release and even flow capabilities. This cover resists both matting and drag. The extra thick polypropylene core resists water, solvents and cracking.



These **Looped Polymer Roller Covers** are most often used to "back-roll" applied coatings. Color may vary.



Our **Phenolic Roller Covers** are solvent-resistant and are used for the spreading and leveling of applied epoxies and mastics, anti-slip floor coverings and heavier coatings.



These **Grey Carpet Nap Roller Covers** are for the application of adhesives and coatings.

Description	Item No. <b>9"</b> <b>NO END CAPS</b>	Item No. <b>18"</b> <b>WITH END CAPS</b>
Shed-Resistant Epoxy Roller Cover	<b>48030</b>	<b>48031</b>
Looped Polymer Roller Cover	<b>48015</b>	<b>48018</b>
Phenolic Roller Cover	<b>48025</b>	<b>48019</b>
Grey Carpet Nap Roller Cover	<b>48014</b>	<b>48017</b>

## Roller Frames

### 9" Universal Roller Frame

This frame is for 9" rollers and has a quick release spring that prevents roller slippage, smooth bearings for reliable applications, a polypropylene grip and a threaded handle adapter. It is one of the best universal roller frames on the market.



### 9" Economy Universal Roller Frame

This traditional "paint roller" style frame has an added "anti-slip" feature and is for use with any 9" roller cover. The handle contains a threaded handle adapter.

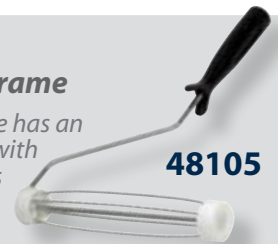

### 9" - 18" Adjustable Roller Frame ...*simply the best*

This frame adjusts to hold all roller covers from 9" to 18" wide. It has a rigid and durable steel frame with a threaded handle adapter, yet weighs less than one pound. This is the best adjustable roller frame available. Any roller used with this frame needs end caps. (see page 13)



### 18" Non-Adjustable Roller Frame

This lightweight, yet durable polypropylene 18" non-adjustable frame can accommodate any of the 18" roller covers we offer. This frame offers a threaded handle adapter and the fiberglass-reinforced nylon legs are replaceable. Any roller used with this frame needs end caps. (see page 13)



**48118**  
Set of 2 Replaceable Legs - SA30006

### Heavy-Duty Fixed Aluminum Frames



These are the most durable frames on the market. **They are available in widths of 9", 18", 24" and 36"** and can be used with any of our roller covers. Our own design, it is the same frame used with our spiked and aluminum rollers. The frames can be ordered with either a threaded handle adapter or with a fixed handle assembly. These heavy-duty solid aluminum frames are solvent-resistant and can be easily cleaned after each use. **Special 3/8" post hole end caps are available for use with these exclusive frames when using 9"-36" roller covers. These polypropylene end caps are used to adapt the frames to any 1-1/2" roller. They are sold in quantities of 1 pair or a pack of 24.**



MWR Item No.	Description
<b>SA30045</b>	<b>3/8" End Caps (Set of 2)</b>
<b>SA30048</b>	<b>3/8" End Caps (Pack of 24)</b>

Description	Frame Width			
	Item No. <b>9"</b>	Item No. <b>18"</b>	Item No. <b>24"</b>	Item No. <b>36"</b>
Heavy-Duty Aluminum Frame with Threaded Handle Adapter	<b>60108</b>	<b>60110</b>	<b>60113</b>	<b>60115</b>
Heavy-Duty Aluminum Frame with 66" PCAH*	<b>60109</b>	<b>60112</b>	<b>60114</b>	<b>60116</b>

\*Powder-Coated Aluminum Handle



# Ribbed Rollers

*...a traditional tank-lining tool...with many other creative uses*

Ribbed rollers are used to evenly distribute resin and other bonding materials when installing fiberglass and other high performance fabric and mesh laminate reinforcement systems. The use of these rollers enhances the fiberglass/fabric saturation and containment, while removing air bubbles and pockets. **These rollers are useful in the installation of tank linings, concrete secondary containment systems and concrete mortar laminate reinforcement flooring applications.** Aluminum rollers are the industry standard. All styles have fins designed with just enough angle to increase strength without sacrificing air relief. These rollers are designed to reduce sheared fiber by insuring a radius is machined on each fin. Resin can be burned off with a torch.

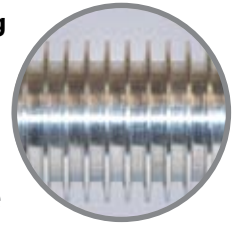

## Replaceable Sleeve Ribbed Rollers

These aluminum rollers fit directly on standard paint roller frames. They have a 2" diameter with a 1.5" diameter center to slip over paint roller frames just like a paint roller cover. The rollers are made from strong 6063 aluminum and are machined to exacting standards of the 2" aluminum rollers shown below. They are sold as complete tools, with replacement sleeves available.

MWR Item No.	Description
48334	4" Aluminum Ribbed Roller, 2" Diameter, Paint Frame - <b>Complete Tool</b>
48337	7" Aluminum Ribbed Roller, 2" Diameter, Paint Frame - <b>Complete Tool</b>
48339	9" Aluminum Ribbed Roller, 2" Diameter, Paint Frame - <b>Complete Tool</b>
48304	4" x 2" Aluminum Ribbed Roller <b>Replacement Sleeve</b> , 1-1/2" ID
48307	7" x 2" Aluminum Ribbed Roller <b>Replacement Sleeve</b> , 1-1/2" ID
48309	9" x 2" Aluminum Ribbed Roller <b>Replacement Sleeve</b> , 1-1/2" ID
48124	4" Heavy-Duty <b>Roller Frame</b> with Threaded Handle Adapter
48127	7" Heavy-Duty <b>Roller Frame</b> with Threaded Handle Adapter
48129	9" Heavy-Duty <b>Roller Frame</b> with Threaded Handle Adapter



## Ribbed Rollers with Wooden Handles

These aluminum rollers have a traditional deep fin, straight groove design. Machined radius fin corners reduce glass fiber shearing. They have reduced clearance for less resin contamination. These rollers come on strong galvanized steel frames with undersize handle bore for tight fit and long life. The wood handles are steel ferruled and accept standard threaded extension handles (see page 18).

MWR Item No.	Description
48313	3" Aluminum Ribbed Roller, 1" Diameter, Wood Handle - <b>Complete Tool</b>
48316	6" Aluminum Ribbed Roller, 1" Diameter, Wood Handle - <b>Complete Tool</b>
48326	6" Aluminum Ribbed Roller, 2" Diameter, Wood Handle - <b>Complete Tool</b>
48329	9" Aluminum Ribbed Roller, 2" Diameter, Wood Handle - <b>Complete Tool</b>



## Specialty Ribbed Rollers

These specialty rollers are designed for concave surfaces and filets where flat rollers are not effective. All of these rollers come with strong steel frames and ferrule reinforced wood handles with threaded handle adapters that accept standard extension handles (see page 18 for handles). All of these rollers are machined with the deepest fins possible for efficient air relief and excellent lay up properties.

MWR Item No.	Description
48321	3/4" Aluminum <b>Corner Filet Ribbed Roller</b> , 2-1/2" Diameter - <b>Complete Tool</b>
48323	3" Aluminum <b>Barrel Radius Ribbed Roller</b> , 2" Diameter - <b>Complete Tool</b>
48310	3" Aluminum <b>Inverted Radius Ribbed Roller</b> , 1" Diameter - <b>Complete Tool</b>



## Fiberglass Scissors

These 10" Knife-Edge Fiberglass Scissors are very rigid and American Made. The knife edge design insures clean, crisp shearing action for all fiberglass materials. **The increased blade angle of 45° over the 15° angle of standard scissors reduces effort and leaves a cleaner, more even cut.**



48300

# Finishing Tools

## Spiked Rollers

**MADE IN THE USA**

We are one of the very few manufacturers in the world to offer rigid solvent-resistant and aluminum cored polypropylene spiked rollers for the floor coating industry.

These spiked rollers are vital in ensuring proper floor coating material adhesion. They are designed to be used on freshly applied floor coatings for the purpose of releasing trapped gas as well as to assist in the leveling process of several varieties of floor coatings. These rollers are easy to clean, allowing for repeated use. The applicator should also wear spiked shoes while using a spiked roller (see page 6).

We manufacture our spikes and end caps out of solvent-resistant High-Density (HD) and Ultra-High Molecular Weight (UHMW) Polyethylene, respectively, for easier cleanup and extended wear. We're sure you will find these tools worth cleaning! Spikes are available in 7/16", 9/16" and 13/16" lengths. Our most popular widths are 9", 18" and 24". Our rollers also come in 36" and 48" widths, which are preferred by some applicators when very large, flat areas need to be treated quickly. We also have 1-1/2" and 3" widths on special frames for very tight areas. All of our rollers, 9" or wider, come with a heavy-duty aluminum frame and high-grade stainless steel axles and our superior gusset bracing with a maximum strength threaded handle adapter. Our 9" rollers also come on a special radial frame with a threaded handle adapter. (See 59009 below). The 1-1/2" and 3" rollers come on special handled frames. (Standard cage style paint-roller frames do not work with our 9" Spiked Rollers). Replacement rollers for all width and spike lengths are available as are replacement frame assemblies (see page 14).

- 1-1/2" with 7/16" spikes - 59001
- 3" with 7/16" spikes - 59003
- 3" with 9/16" spikes - 59403
- 3" with 13/16" spikes - 59103



For Handle Options



### 9/16" Super Sharp (44 Spikes)

#### Heavy-Duty Aluminum Frame

Head Width	Radial Roller Frame	Threaded Handle Adapter	66" Handle	Replacement Roller
9"	59458	59459	59559	SA10062
18"	-	59468	59568	SA10063
24"	-	59474	59574	SA10064
36"	-	59486	59586	SA10065
48"	-	59498	59598	SA10066

### 7/16" Super Sharp (33 Spikes)

#### Heavy-Duty Aluminum Frame

Head Width	Radial Roller Frame	Threaded Handle Adapter	66" Handle	Replacement Roller
9"	59009	59209	59509	SA10043
18"	-	59218	59518	SA10023
24"	-	59224	59524	SA10025
36"	-	59236	59536	SA10026
48"	-	59248	59548	SA10027

### 13/16" Super Sharp (33 Spikes)

#### Heavy-Duty Aluminum Frame

Head Width	Radial Roller Frame	Threaded Handle Adapter	66" Handle	Replacement Roller
9"	59109	59309	59609	SA10044
18"	-	59318	59618	SA10029
24"	-	59324	59624	SA10030
36"	-	59336	59636	SA10031
48"	-	59348	59648	SA10032

### Helpful Hints...

Many factors can contribute to the creation of trapped gas bubbles in freshly applied protective coatings, particularly on floors. Our 7/16" and 13/16" Super Sharp Spiked Rollers are effectively used on most floor coatings and your choice between the two depends on the mil thickness specifications of the material being applied.

Where a great abundance of bubbles are anticipated or seen, our 9/16" Super Sharp Spiked Rollers are ideal because of the greater number of spikes per square inch of roller surface.

Most often, either the 7/16" or the 13/16" Super Sharp Spiked Rollers are adequate to get the job done.

## "Metal-Tined" Spiked Roller Covers

*A more dense steel tine configuration, modeled after the traditional "porcupine" roller. These rollers have a phenolic core. The 18" cover comes with 1/4" holed end caps.*



1/2" Tines

Description	Item No. 9" NO END CAPS	Item No. 18" WITH END CAPS
Metal-Tined Spiked Roller Cover	48090	48091

For Frame Options

See P. 14

## Back-Rolling Covers

*These rollers are preferred for "back-rolling"; the finishing of applied floor coatings after the initial application.*

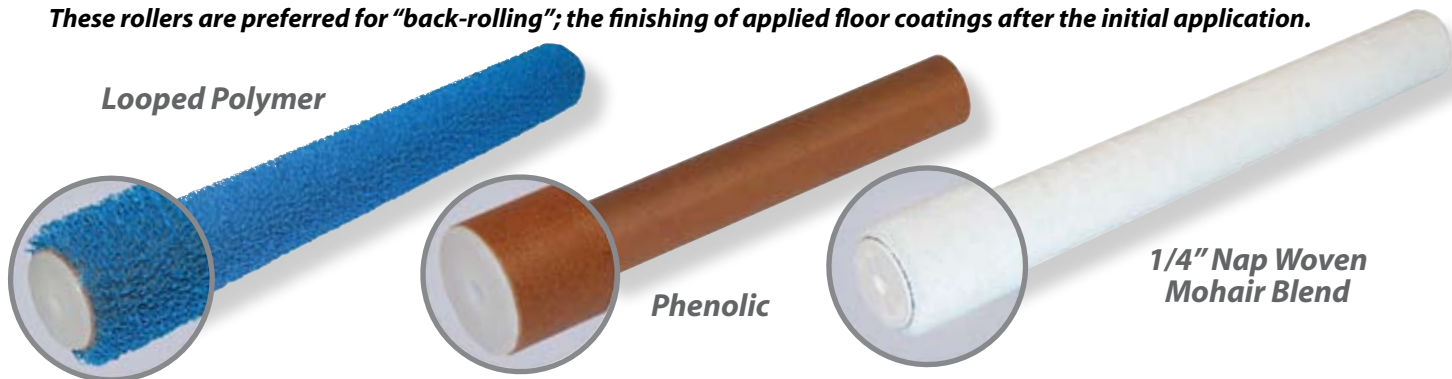

Looped Polymer

Phenolic

1/4" Nap Woven Mohair Blend

Description	Item No. 9" NO END CAPS	Item No. 18" WITH END CAPS
Looped Polymer Roller Cover (colors may vary)	48015	48018
Phenolic Roller Cover	48025	48019
Premium Mohair Blend 1/4" Nap Cover	48022	48021

## The Original "Magic Trowel"

*The Magic Trowel is used to smooth the surface of applied cementitious overlays, particularly overlays of a more fluid consistency. A very effective finishing tool capable of creating a flawless surface.*

Available in 12", 18", 22", 24" and 26" widths



47417

MWR Item No.	Description	Blade Size in.
47415	Magic Trowel	12
47416	Magic Trowel	18
47417	Magic Trowel	22
47418	Magic Trowel	24
47419	Magic Trowel	26



## Smoother/Spreader

*This tool is lightweight, yet durable. It features a 22" frame with a 23-1/2" x 2" heat-treated steel blade, fan-shaped for next to wall coverage, and a reversible "threaded" handle adapter assembly allowing for use as a smoother or spreader. Spread material with the blade in a vertical position (see below). Flip the tool over and smooth the surface as shown. This is a "core" tool...*

See handle options on page 18  
Use #SP20215 (wood) or aluminum powder-coated handle.



Long handled "troweling" action, too...



MWR Item No.	Description
78930	Smoother with Threaded Handle Adapter

# Accessories

## Low Viscosity Mixers

The **Pro-Grade** mixers are the choice of many contractors. **These mixers have low shear for minimal air entrapment while mixing.** The Pro-Grade mixers are constructed of quality powder-coated steel and are available in 2 sizes; a 1-2 gallon paddle with a 3-1/2" turbine style head on a 19-3/4" x 5/16" diameter hex shaft or a 2-5 gallon paddle with a 4-3/4" turbine style head on a 23-1/2" x 3/8" diameter hex shaft.

**Pro-Grade**



47434

47444

47432

**Jiffy**

**Jiffy Mixers** are also available in two sizes; a 1-2 gallon and a 2-5 gallon. the mixers are made of 304 stainless steel and fit all 1/4" - 3/4" chucked power tools. **The blade actions are characterized by a smooth, thorough, non-air sucking and non-splashing action.**

MWR Item No.	Description
47442	1-2 Gallon Small Pro-Grade Mixing Paddle
47444	2-5 Gallon Large Pro-Grade Mixing Paddle
47432	1-2 Gallon Small Jiffy Mixer
47434	2-5 Gallon Large Jiffy Mixer



47442

## Level Pegs

**Stick-Ems™ Level Pegs** are used to achieve a level surface. Use them with your leveling unit. **Cut to height and stick this flexible, self-adhesive rubber/vinyl peg right to the substrate.** Pour leveling product right over the top. The peg will not float to the surface and becomes part of the cement matrix. Gauged in millimeters up to 65 mm (2-1/2").



Description	Pack of 100	Carton of 1000/10 Pks
Stick-Ems™ Level Pegs	46285	46280

## Solvent-Resistant Gloves



**These nitrile, flock-lined, form fitting gloves are resistant to solvents used regularly within the coating industry.** They are available in three sizes.

Description	Size 9 - L	Size 10 - XL	Size 11 - XXL
Solvent-Resistant Gloves (Pair)	46209	46210	46211

## Handle Options

**Powder-Coated Aluminum Handles with Milled Threaded Tips** - for use with threaded handle adapters. **We designed this milled threaded tip handle to provide the "tightest" fit with our tools that are available with our exclusive threaded handle adapter.** These handles have a durable, milled threaded aluminum tip for added strength - no more broken tips - and come in 60", 66", and 82" lengths. We also have a 60" extension handle available to use with these handles which **has a threaded tip on one end and a threaded receptacle on the other end.**

### Fiberglass Extension Handle

This fiberglass, double-lock, telescopic handle extends from 3 to 6 feet. It has a milled threaded tip that is virtually unbreakable.

**MADE IN THE USA EXCLUSIVE**



A. / B. / C.

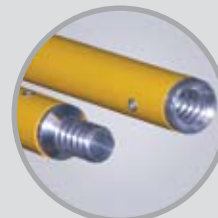

D.



E.

**Hardwood Handles**  
We offer a variety of high quality hardwood handles, with either a tapered tip or a metal threaded tip.

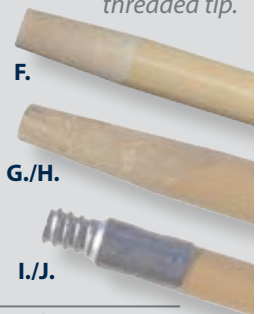

F.

G./H.

I./J.

MWR Item No.	Description
A. SA20173	60" PCA* Handle w/ Aluminum Threaded Tip
B. SA20174	66" PCA* Handle w/ Aluminum Threaded Tip
C. SA20175	82" PCA* Handle w/ Aluminum Threaded Tip
D. SA20228	60" PCA* Extension Handle for above
E. SA20221	3'-6' Fiberglass Telescopic Extension Handle

\*Powder-Coated Aluminum

MWR Item No.	Description
F. SP20163	15/16" x 48" Hardwood Handle, Tapered Tip
G. SP20220	1-1/8" x 60" Hardwood Handle, Tapered Tip
H. SP20221	1-1/8" x 72" Hardwood Handle, Tapered Tip
I. SP20215	15/16" x 60" Hardwood Handle, Metal Threaded Tip
J. SP20216	15/16" x 72" Hardwood Handle, Metal Threaded Tip

# Terrazzo Tools

## Terrazzo Double Rollers & Edger

**MADE IN THE USA  
EXCLUSIVE**

This 24" **Double Roller** configuration is available with stub rollers or with smooth aluminum rollers and **both have adjustable weight capability**. The stub double rollers are used for terrazzo and high-build impregnated flooring systems to ensure the aggregates are thoroughly placed and evenly distributed throughout the floor. The aluminum double rollers are used for polymer flooring systems to ensure the filler (aggregate, paint flakes, vinyl chips, metallic filler) is uniformly and fully saturated into the wet polymer matrix. We recommend using these rollers with our fixed 66" powder-coated aluminum handle for maximum strength. **The roller hubs have ball bearings and stainless steel axles and come in a heavy-duty, powder-coated steel frame which provides easy adjustment of weight load, allowing for the increase or decrease in downward pressure.** The 6" **Edger** comes with stub spikes and works right along with the Stub Double Roller, fitting into tight areas and along walls where the double roller cannot be used effectively. It comes with a rigid steel frame and axle which is weighted. It comes with a threaded handle adapter or with a 66" powder-coated aluminum handle.

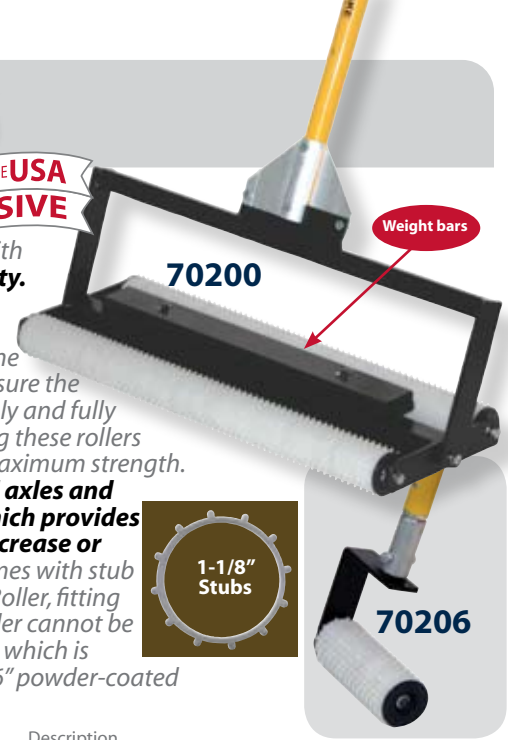

70211

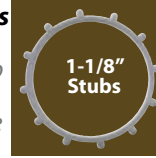

1-1/8" Stubs

Weight bars

70206

Description	24" Stub Roller	24" Aluminum Roller
Terrazzo Double Roller Frame with 66" PCAH*	<b>70200</b>	<b>70210</b>
Terrazzo Double Roller Frame with THA **	<b>70201</b>	<b>70211</b>
Replacement Roller (1 Roller)	<b>SA10185</b>	<b>SA10184</b>

MWR Item No.	Description
<b>70206</b>	6" Terrazzo Edger with THA**
<b>70207</b>	6" Terrazzo Edger with 66" PCAH*
<b>SA10186</b>	6" Edger Replacement Roller

\*Powder-Coated Aluminum Handle \*\*Threaded Handle Adapter

# Specialty Rollers

## Blunt Spiked & Stub Rollers

We make a number of specialty tools featuring these hybrid spikes. Unlike our sharp-tipped spiked rollers, used to remove trapped bubbles from freshly applied floor coatings, these roller covers are actually used as application tools. **They are often used to force and compress aggregate materials into a variety of overlays, or create a special surface finish. We can custom make a variety of tools using the "blunt" and "stub" spikes...and because of the hollow aluminum core, these rollers can be weighted.**

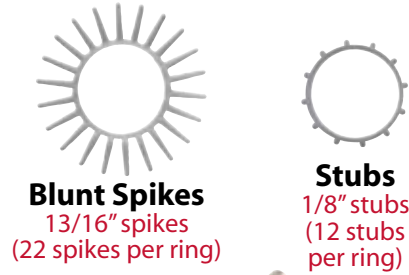

**Blunt Spikes**  
13/16" spikes  
(22 spikes per ring)

**Stubs**  
1/8" stubs  
(12 stubs per ring)



59774

## Membrane & Blanket Roller Squeegee

A hard rubber non-absorbent roller squeegee with just enough flex to make it an ideal "roll-over" tool when applying membranes and curing blankets. **Rolls out air pockets and water very effectively.** One of those "must-have" tools that saves both time and money.



24" - 70624  
36" - 70636  
48" - 70648

Description	Roller Width				
	Item No. 9"	Item No. 18"	Item No. 24"	Item No. 36"	Item No. 48"
Blunt Spiked Roller on Radial Roller Frame	<b>59108</b>	-	-	-	-
Blunt Spiked Roller on Heavy-Duty Aluminum Frame with THA*	<b>59709</b>	<b>59718</b>	<b>59724</b>	<b>59736</b>	<b>59748</b>
Blunt Spiked Roller on Heavy-Duty Aluminum Frame with 66" PCAH**	<b>59809</b>	<b>59818</b>	<b>59824</b>	<b>59836</b>	<b>59848</b>
Replacement Blunt Spiked Roller	<b>SA10013</b>	<b>SA10014</b>	<b>SA10015</b>	<b>SA10016</b>	<b>SA10017</b>
Stub Roller on Radial Roller Frame	<b>59758</b>	-	-	-	-
Stub Roller on Heavy-Duty Aluminum Frame with THA*	<b>59759</b>	<b>59768</b>	<b>59774</b>	-	-
Replacement Stub Roller	<b>SA10072</b>	<b>SA10073</b>	<b>SA10074</b>	-	-

\*Threaded Handle Adapter \*\*Powder-Coated Aluminum Handle

# Decorative Concrete Tools

**Our Most Popular Sizes**



1/8" - 57082

1/4" - 57084

3/8" - 57086

**CAM® Gauge Rakes** A patented "goof-proof" tool which applies a range of materials at a precise, specified, and uniform depth. For use in applying decorative concrete "toppings," self leveling/high performance floor coating materials, and underlayments in the floor-covering markets. CAM® depth settings range from 1/32" to 1-1/2". A must have tool for the decorative concrete and floor coating contractor.

We use a "radial" edge CAM® design which maintains uniform coating thickness, even at varying handle angles and lengths.



**See P. 10 & 11** For more CAM® Gauge Rake information

10" Hand-Held Frame - **57044**

24" Frame with Threaded Handle Adapter - **57000**

24" Frame with 66" Powder-Coated Aluminum Handle - **57001**

**EXCLUSIVE MADE IN THE USA**

**57001**  
24" frame with 66" handle

**CAM® Sets are also available in "3-packs"...**  
See Page 10

**Larger CAM® Sets:**

**5/8" CAM® Set 57090 (size 10)**  
3 settings

**1" CAM® Set 57096 (size 16)**  
3 settings

**1-1/2" CAM® Set 57104 (size 24)**  
2 settings

**CAM® Gauge Rake Frames and CAM® Sets are sold separately**

**Level "Pegs"**

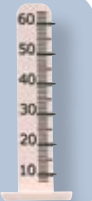

**See P. 18**



1/32" size A  
57078

1/24" size B  
57079

1/16" size 1  
57081

1/8" size 2  
57082

3/16" size 3  
57083

1/4" size 4  
57084

5/16" size 5  
57085

3/8" size 6  
57086

1/2" size 8  
57088

## Spiked Shoes



All spiked shoes come with a durable snap-lock buckle system

### Black Spiked Shoes



**Rounded-Tip Spiked Shoes**  
Don't penetrate that primer...3/4" rounded tip, 13 spikes per shoe

- Durable solvent-resistant polypropylene
- Snap-lock buckle system
- Sharp or Rounded tip spikes
- 13 specially placed spikes per shoe
- Replacement spikes (see below)

**Rounded Tip Spiked Shoes - 46112**

**Rounded Tip Replacement Spikes - 46122**

**Sharp Tip Spiked Shoes - 46106**

**Sharp Tip Replacement Spikes - 46125**

## "Flexible Bed" Spiked Shoes

made for Midwest Rake Co. by



- **Revolutionary** - perfect fit, balance and flexibility
- Toe and heel guards
- Snap-lock buckle system
- 1/2" spike length
- 20 replaceable spikes per shoe (18 on small size)
- Fits like a shoe

**See P. 6**

MWR Item No.	Description
<b>46140</b>	Size Small (Shoe size 6 to 7-1/2)
<b>46141</b>	Size Medium (Shoe size 8 to 9-1/2)
<b>46142</b>	Size Large (Shoe size 10 to 11-1/2)
<b>46143</b>	Size Extra-Large (Shoe size 12 to 13-1/2)
<b>46129</b>	Replacement Spikes (set of 40)

Decorative Concrete Tools

20

# Notched Application Squeegees...*the right tool for primers*

*Ideal for use with primer and other self-leveling materials, these quality clamp-style squeegees allow for easy blade exchange and are available with threaded handle adapters or "fixed" powder-coated aluminum handles. The most durable on the market, these quality frames can be used over and over again, requiring only the purchase of replacement blades. Many additional widths and notch sizes are available. The product shown has a 24" wide head and a solvent-resistant "reversible" red rubber blade - flat (no notch) on one side, 1/8" on the other side. A great value.*



**24" with Threaded Handle Adapter - 78129**  
**Replacement Blade - 79730**



**For complete Application Squeegee information**

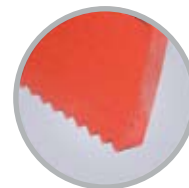

## Flexible Blade Smoother

*This flexible 24" x 5" rounded corner steel blade is bent and angled to maximize blade contact with a range of surface coating materials. This smoothing tool can also serve as a spreading tool and even a surface preparation tool. It is most often used when troweling and/or smoothing overlay/underlay material (toppings) of a more cementitious composition prior to surface treatment. The blade is contained in a durable aluminum frame with our superior gusset bracing system. This tool is available with a threaded handle adapter or with a 66" powder-coated aluminum handle. Square cornered blades are also available.*



MWR Item No.	Description	Blade Style
<b>78906</b>	With Threaded Handle Adapter	Round
<b>78907</b>	With 66" Powder-Coated Aluminum Handle	Round
<b>78902</b>	With Threaded Handle Adapter	Square
<b>78903</b>	With 66" Powder-Coated Aluminum Handle	Square

## *A must...* Smoother/Spreader

*This tool is lightweight, yet durable. It features a 22" frame with a 23-1/2" x 2" heat-treated steel blade, fan-shaped for next to wall coverage, and a reversible "threaded" handle adapter assembly allowing for use as a smoother or spreader. Spread material with the blade in a vertical position (see below). Flip the tool over and smooth the surface as shown. This is a "core" tool...*

*See handle options on page 18 Use #SP20215 (wood) or aluminum powder-coated handle.*



**Long handled "troweling" action, too...**

MWR Item No.	Description
<b>78930</b>	Smoother with Threaded Handle Adapter

## Topping and Underlayment "Super Squeegee"

*A 24" low-angle/clamp style frame with a durable gusset bracing system is combined with a rounded edge, 3" exposed neoprene rubber blade. The result is a tool that effectively eliminates the need for troweling. A true spreading and smoothing squeegee allowing the contractor opportunity to save time and money when working with "toppings", underlayments and "high-mil" self-leveling materials. The contractor-friendly head to handle to surface angle has made this a very effective and popular tool.*

**3" Neoprene Rubber Blade**



MWR Item No.	Description	Blade Size in.
<b>78601</b>	Squeegee with Threaded Handle Adapter	24
<b>78602</b>	Squeegee with 66" Powder-Coated Aluminum Handle	24
<b>SP50071</b>	Replacement Blade	24

## 15 Gallon Mixing Barrel

Mixing barrels can be hard to come by...reconditioned or new. The 15 gallon mixing barrel (European style) with fixed side handles and sealing lid is the standard. Used to mix more cementitious materials prior to application.

**Please call 1-800-815-7253 for availability and pricing.**

- HD Polyethylene
- Belted lids
- Web or pegged handles

(Features of the reconditioned barrels may vary)

MWR Item No.	Description
<b>46240</b>	<b>New</b> Mixing Barrel
<b>46250</b>	Reconditioned Mixing Barrel



## High Viscosity Mixing Paddles

These mixers are used by those in the decorative concrete, stamping and terazzo markets. The "football" shaped cage configurations are ideal for mixing more viscous "topping" and impregnated and cementitious materials. The **larger 10" x 6" head** is designed for barrel mixing. The **smaller 6" x 4" head** is ideal for 5 gallon quantities. Both mixers effectively remove air without splash-out. Both have an overall length of 26" with a hex shaft.

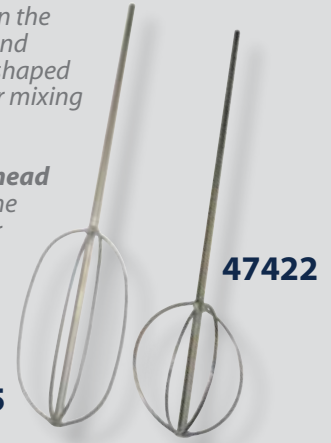

**47425**

MWR Item No.	Description
<b>47422</b>	Small 5 Gallon Mixer
<b>47425</b>	Large Mixer

**Other mixer styles are available - see page 18**

## Trowels & Floats

**MADE IN THE USA**

Tempered, ground and polished high carbon spring steel. Blades are fastened with hardened steel rivets. Wooden handles for better gripping power. Selected by manufacturers "technical specialists" for decorative concrete and floor coating applications. Hard to find sizes...



### Finishing Trowels

4" x 12" - **47404**  
4" x 16" - **47405**



### Rounded End Trowels

4" x 16" - **47465**  
4" x 18" - **47466**



### Rounded End "Deco" Finishing Trowels

3" x 12" - **47475**  
3" x 16" - **47477**



### More Flexible "Spring Form" Trowel

5" x 16" - **47470**

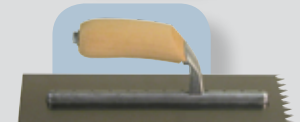

### Notched Trowels

4-1/2" x 11" overall  
3/16" V-Notch - **47406**  
1/4" V-Notch - **47403**  
1/2" V-Notch - **47402**



### Heavy-Duty Cove Trowels

High Carbon Blue Steel  
7-1/2" x 5-3/4" overall  
1" Radius - **47414**  
3/4" Radius - **47409**



### Flexible Radius Trowel

Flexible Rubber Blade  
6-1/2" x 9-1/2" - **46010**

## The Original "Magic Trowel"

The Magic Trowel is used to smooth the surface of applied cementitious overlays, particularly overlays of a more fluid consistency. A very effective finishing tool capable of creating a flawless surface.

Available in 12", 18", 22", 24" and 26" widths



**47417**

MWR Item No.	Description	Blade Size in.
<b>47415</b>	Magic Trowel	<b>12</b>
<b>47416</b>	Magic Trowel	<b>18</b>
<b>47417</b>	Magic Trowel	<b>22</b>
<b>47418</b>	Magic Trowel	<b>24</b>
<b>47419</b>	Magic Trowel	<b>26</b>

## Raised Edge Border/Hand Floats

Heavy-duty raised edges "all-around" make these hand floats / smoothers / trowels ideal tools for any decorative concrete contractor... no cutting edges and a great tool when working with high viscosity / cementitious materials and other "trowelable" materials.



MWR Item No.	Description
<b>47500</b>	8" x 6" Stainless Steel Float
<b>47510</b>	15" x 6" Float

# Measuring Wheels

**★ It all keys off of the "surface area" to be coated with any product or system. Accurate measurements are critical to any protective coating or decorative concrete application. We offer a range of quality measuring wheels, but two special wheels that best fit the floor coating and decorative concrete markets are shown below. Please call us for information on the other models we carry or visit our website, [midwestrake.com](http://midwestrake.com).**

## Small Telescoping Measuring Wheel

- Wheel has **1' circumference** with a **4" diameter**
- Handle **telescopes from 17" to 38"**
- Fits in a toolbox or briefcase
- Geared counter
- Measurements in feet and inches up to 9,999 feet, 11 inches without resetting
- Adds while rolling forward and subtracts when pulled in reverse
- Weighs less than 2 pounds
- Individually boxed



85701



17" telescopes to 38"

## Wide-Trak Measuring Wheel

- Solid and **wider wheel for excellent balance**
- Wheel has **2' circumference** with a **7-1/2" diameter**
- Heavy-duty 3/4" steel handle
- 5 digit, easy-to-read counter
- Measurements in feet up to 99,999 feet
- Individually boxed



85712

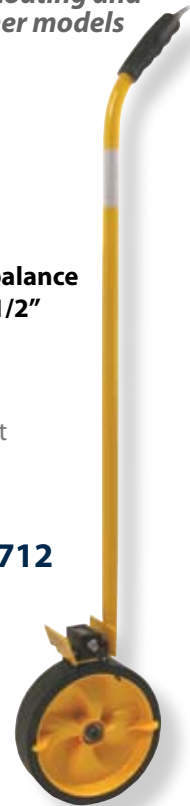

MWR Item No.	Description
85701	Small Telescoping 1' Measuring Wheel

MWR Item No.	Description
85712	Wide-Trak 2' Measuring Wheel

# In-Store Display Unit

*This "In-Store Display Unit" is a three-sided, free-standing unit comprised of three 2' x 8' black wire grid panels. This unit can be placed against a wall, used as an end-of-aisle display or as a free standing unit. **The unit does not come with tools**; you can customize the unit with the tools your customers want and need.*

*You customize the unit with tools to meet your customers' needs...*



**Unit includes:** 58015

- 3 - 2' x 8' black wire grid panels
- 3-Coating Application Tools signs
- 24-4" hooks
- 14-8" hooks
- 2-Literature baskets
- 30-Cable ties
- 25-High Performance Industrial/Commercial Floor & Surface Coating Tools & Decorative Concrete Application and Finishing Tools Catalogs

MWR Item No.	Description
58015	In-Store Display Unit <b>(NO TOOLS)</b>

*If they see it... You can sell it.*



*One Company...  
serving many markets,  
when quality counts.*



---

**Midwest Rake Company, LLC** • P.O. Box 1674 • Warsaw, Indiana 46581-1674  
800-815-RAKE (7253) • 574-267-8508 Fax • [www.midwestrake.com](http://www.midwestrake.com)